

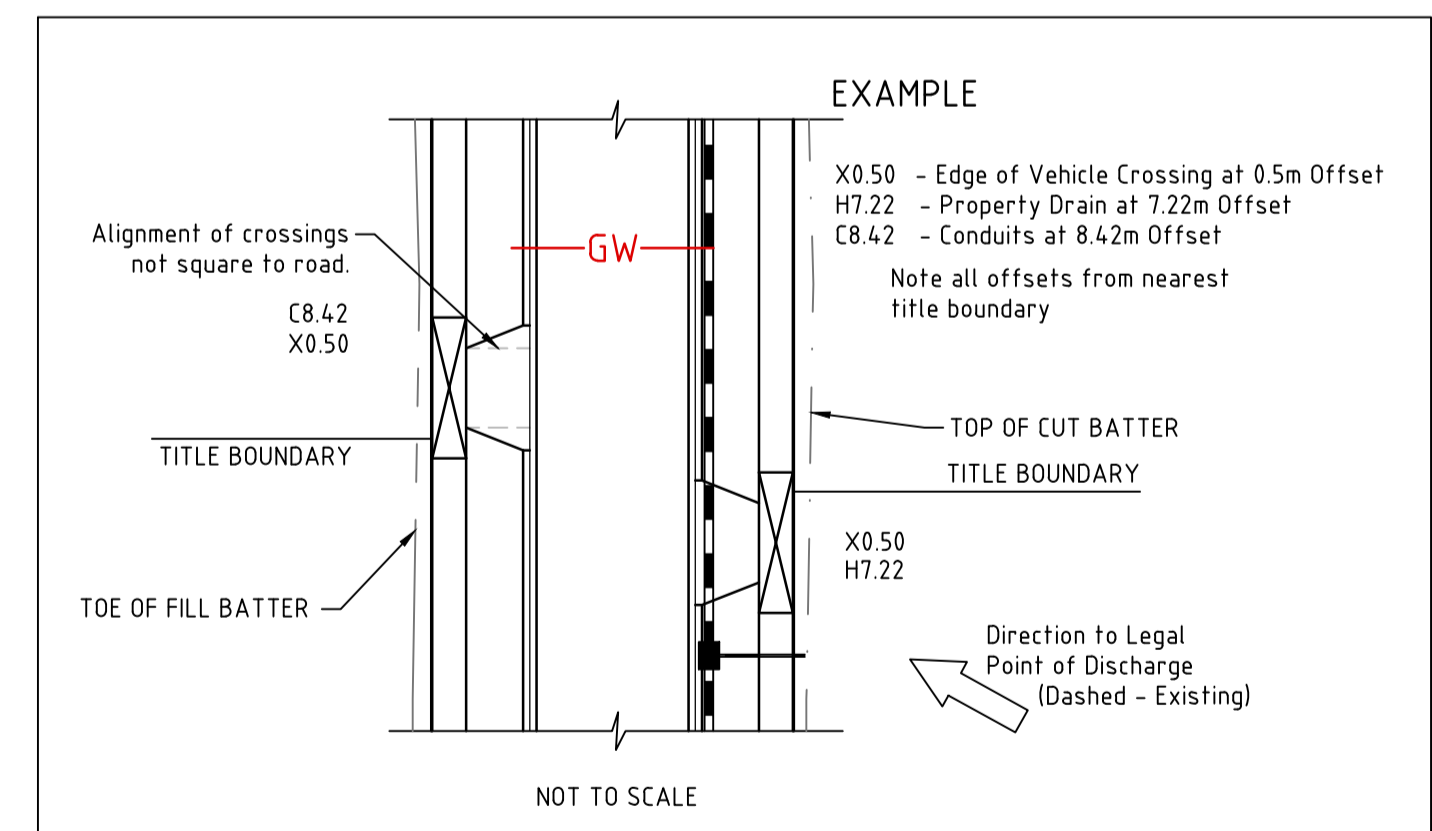

**LEGEND**

- FILL IN EXCESS OF 200mm
- CUT IN EXCESS OF 200mm
- THIS PLAN SHOWS APPROXIMATE EXTENTS OF CUT AND FILL TO BE UNDERTAKEN DURING CONSTRUCTION OF THE WORKS BASED ON THE EXISTING SITE SURFACE LEVELS AND PROPOSED FINISHED DESIGN LEVELS SHOWN.
- THE EXTENT OF FILL SHOWN IS BASED ON DESIGN AND MAY BE SUBJECT TO CHANGE DURING CONSTRUCTION.
- THE DEPTH OF TOP DRESSING FILL MAY VARY BY UP TO 0.15m.
- PROPOSED PARKING BAY



**WARNING**  
 BEWARE OF UNDERGROUND SERVICES  
 THE LOCATIONS OF UNDERGROUND SERVICES ARE APPROXIMATE ONLY AND THEIR EXACT POSITION SHOULD BE PROVEN ON SITE. NO GUARANTEE IS GIVEN THAT ALL EXISTING SERVICES ARE SHOWN.

0 5 10 20  
 Scale 1:500 @ A1

**CONSTRUCTION PLAN**

THIS DRAWING IS NOT TO BE COPIED OR SCALED

VERSION	REMARKS	DATE	BY
F	CONSTRUCTION ISSUE	21.11.17	NJR
D	DRIVEWAYS SOUTH SIDE OF ROCKBANK ROAD RELOCATED	19.09.17	NJR
E	PRELIMINARY ISSUE	13.09.17	NJR
C	ROAD NAME AMENDED	29.08.17	AN
B	DRIVEWAY CROSSINGS REVISED HONOUR AVENUE	29.08.17	NJR

LEGEND	
	DRAIN, PROPERTY INLET & PIT
	EX DRAIN & PIT
	HOUSE DRAIN
	SEWER AND MAINTENANCE HOLE
	EX SEWER AND MAINTENANCE HOLE
	WATER MAIN
	EX WATER MAIN, VALVE & HYDRANT
	GAS MAIN
	EX GAS MAIN, VALVE
	TELSTRA SERVICES & PITS
	EX TELSTRA SERVICES & PITS
	RECYCLED WATER
	EX RECYCLED WATER
	ELECTRICAL U.G. SERVICES
	EX ELECTRICAL U.G. SERVICES
	ELECTRICAL SERVICE & PIT
	EX ELECTRICAL ASSETS
	EX ELECTRICAL OVERHEADS
	GAS & WATER CONDUITS
	TOP OF BATTER
	TOE OF BATTER
	FINISHED SURFACE AFTER CUTTING OR FILLING
	TOP OF PROPOSED BATTER
	PROPOSED PAVEMENT OR FOOTPATH SURFACE
	EXISTING OR PROPOSED INVERT LEVEL OF PIPE OR OPEN DRAIN
	TANGENT POINT
	CHAINAGE
	PSM
	STREET SIGN DRAINAGE PIT No.
	TBM
	EX FENCE
	EX WALL OR BUILDING

DRAWN BY	N. ROBINSON	DESIGNED BY	J. BOSCO
MELWAY	131, D10	CHECKED BY	H. DAY
DATUM	AHD	AUTHORISED BY	S. RAVIDA

**REEDS CONSULTING**  
 www.reedsconsulting.com.au  
 engineering@reedsconsulting.com.au

LAND SURVEYING  
 CIVIL ENGINEERING  
 PLANNING  
 DEVELOPMENT CONSULTING

CITY OF CASEY  
 HONOUR VILLAGE ESTATE  
 STAGE 15  
 LAYOUT PLAN

DRAWING No.	15R2	VERSION	F
REFERENCE	22344E/15		
SHEET	2 OF 7		

H:\22344\STAGE 15\CAD\DWG SET\ROAD AND DRAINAGE\22344\_15R2 & 5DWG