

LEGEND

- FILL IN EXCESS OF 200mm
- CUT IN EXCESS OF 200mm
- THIS PLAN SHOWS APPROXIMATE EXTENTS OF CUT AND FILL TO BE UNDERTAKEN DURING CONSTRUCTION OF THE WORKS BASED ON THE EXISTING SITE SURFACE LEVELS AND PROPOSED FINISHED DESIGN LEVELS SHOWN.
- THE EXTENT OF FILL SHOWN IS BASED ON DESIGN AND MAY BE SUBJECT TO CHANGE DURING CONSTRUCTION.
- THE DEPTH OF TOP DRESSING FILL MAY VARY BY UP TO 0.15m.
- PROPOSED PARKING BAY

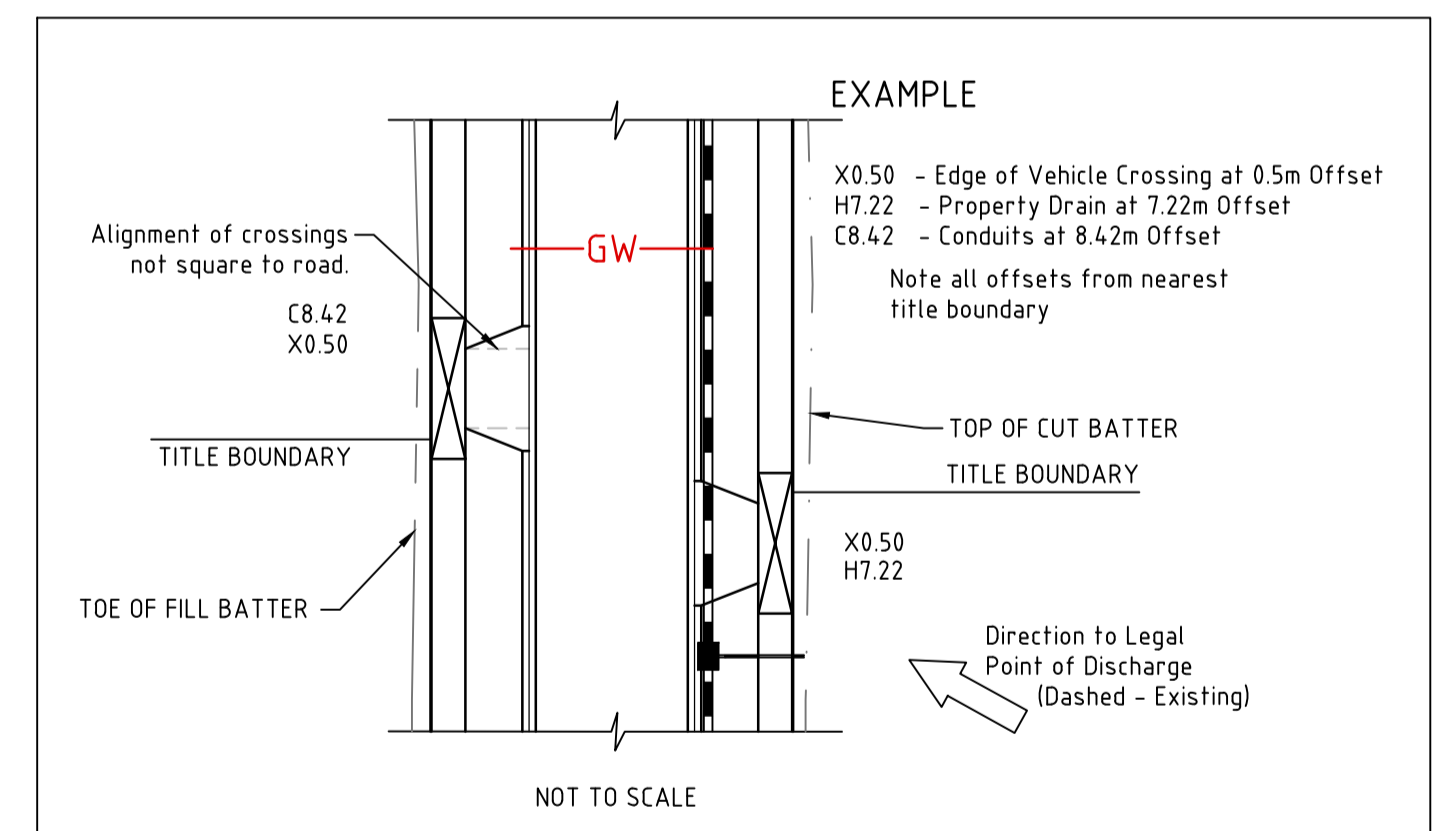

WARNING
BEWARE OF UNDERGROUND SERVICES
THE LOCATIONS OF UNDERGROUND SERVICES ARE APPROXIMATE ONLY AND THEIR EXACT POSITION SHOULD BE PROVEN ON SITE. NO GUARANTEE IS GIVEN THAT ALL EXISTING SERVICES ARE SHOWN.

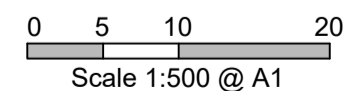

CONSTRUCTION PLAN

THIS DRAWING IS NOT TO BE COPIED OR SCALED

VERSION	REMARKS	DATE	BY
L	LOTS DIMENSIONS AMENDED	23.03.22	JB
K	EXISTING SURFACE LEVELS OF LOTS 1536 TO 1540 ADDED	03.03.22	JB
J	CONDUITS REVISED AND CONSTRUCTION ISSUE	14.10.21	JB
H	DRAINAGE PROPERTY CONNECTIONS AMENDED	30.09.21	KM
G	OUTFALL DRAIN ADDED	24.06.21	KM

LEGEND	
	DRAIN, PROPERTY INLET & PIT
	RECYCLED WATER
	ELECTRICAL U.G. SERVICES
	ELECTRICAL SERVICE & PIT
	GAS MAIN
	GAS & WATER CONDUITS
	TOP OF BATTER
	TOE OF BATTER
	SEWER AND MAINTENANCE HOLE
	EX SEWER AND MAINTENANCE HOLE
	WATER MAIN, VALVE & HYDRANT
	GAS MAIN, VALVE
	TELSTRA SERVICES & PITS
	EX TELSTRA SERVICES & PITS
	EX RECYCLED WATER
	EX ELECTRICAL U.G. SERVICES
	EX ELECTRICAL SERVICE & PIT
	EX GAS MAIN
	EX GAS & WATER CONDUITS
	EX TOP OF BATTER
	EX TOE OF BATTER
	EX SEWER AND MAINTENANCE HOLE
	EX WATER MAIN, VALVE & HYDRANT
	EX GAS MAIN, VALVE
	EX TELSTRA SERVICES & PITS
	STREET SIGN DRAINAGE PIT No. TBM
	EX FENCE OR BUILDING
	F FINISHED SURFACE AFTER CUTTING OR FILLING
	Fb TOP OF PROPOSED BATTER
	P PROPOSED PAVEMENT OR FOOTPATH SURFACE
	IL EXISTING OR PROPOSED INVERT LEVEL OF PIPE OR OPEN DRAIN
	TP TANGENT POINT
	CH CHAINAGE
	PSM

DRAWN BY	N. ROBINSON	DESIGNED BY	J. BOSCO
MELWAY	131, D10	CHECKED BY	H. DAY
DATUM	AHD	AUTHORISED BY	S. RAVIDA

REEDS CONSULTING
www.reedsconsulting.com.au
engineering@reedsconsulting.com.au

LAND SURVEYING
CIVIL ENGINEERING
PLANNING
DEVELOPMENT CONSULTING

CITY OF CASEY
HONOUR VILLAGE ESTATE
STAGE 15
LAYOUT PLAN

DRAWING No.	15R2	VERSION	L
REFERENCE	22344E/15		
SHEET	2 OF 8		

H:\22344_STAGE 15\CADD\DWG SET\ROAD AND DRAINAGE\22344_15R2 & 5.DWG

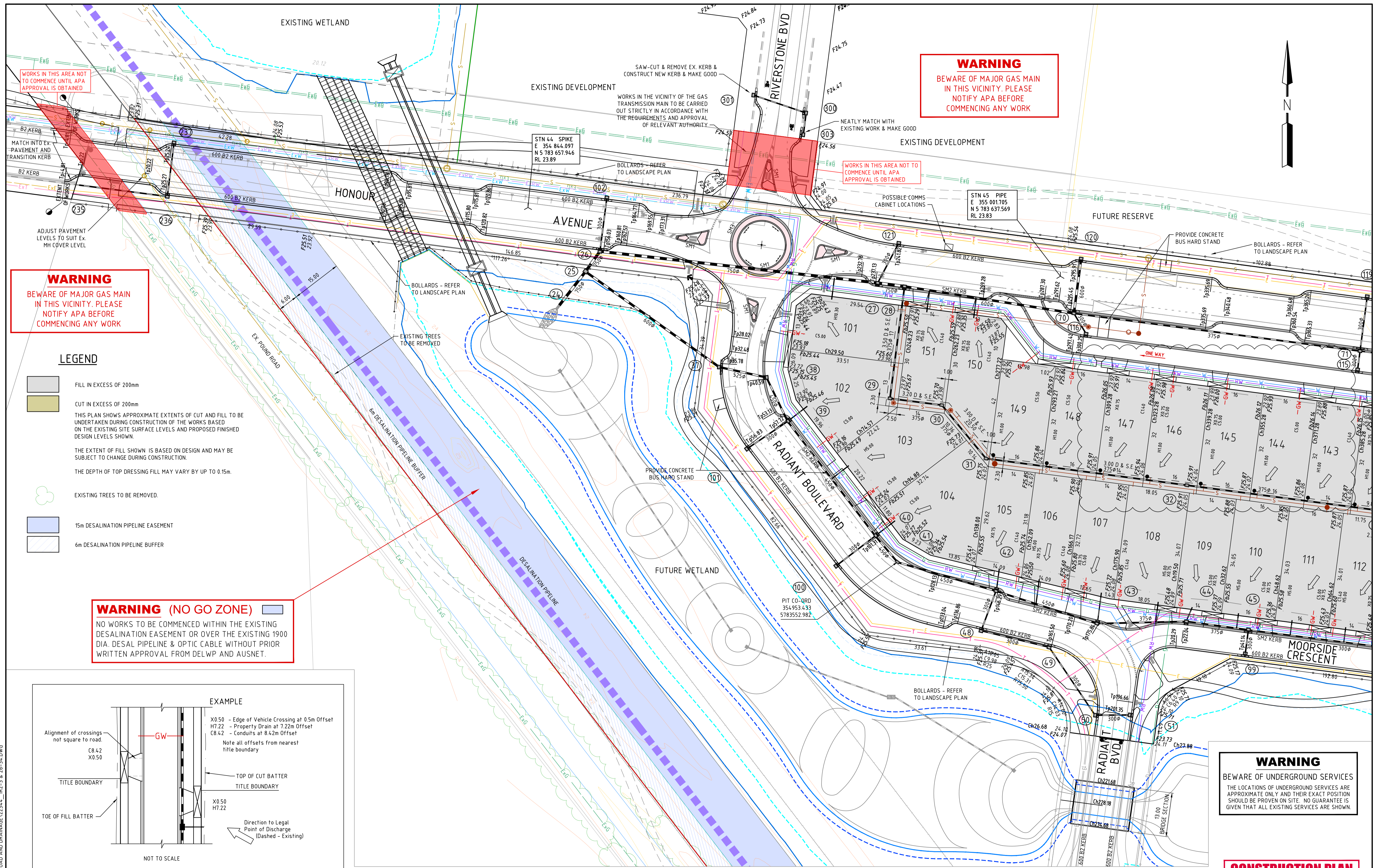

WORKS IN THIS AREA NOT TO COMMENCE UNTIL APA APPROVAL IS OBTAINED

WARNING
BEWARE OF MAJOR GAS MAIN IN THIS VICINITY. PLEASE NOTIFY APA BEFORE COMMENCING ANY WORK

WARNING
BEWARE OF MAJOR GAS MAIN IN THIS VICINITY. PLEASE NOTIFY APA BEFORE COMMENCING ANY WORK

WARNING (NO GO ZONE)
NO WORKS TO BE COMMENCED WITHIN THE EXISTING DESALINATION EASEMENT OR OVER THE EXISTING 1900 DIA. DESAL PIPELINE & OPTIC CABLE WITHOUT PRIOR WRITTEN APPROVAL FROM DELWP AND AUSNET.

LEGEND

- FILL IN EXCESS OF 200mm
- CUT IN EXCESS OF 200mm
- THIS PLAN SHOWS APPROXIMATE EXTENTS OF CUT AND FILL TO BE UNDERTAKEN DURING CONSTRUCTION OF THE WORKS BASED ON THE EXISTING SITE SURFACE LEVELS AND PROPOSED FINISHED DESIGN LEVELS SHOWN.
- THE EXTENT OF FILL SHOWN IS BASED ON DESIGN AND MAY BE SUBJECT TO CHANGE DURING CONSTRUCTION.
- THE DEPTH OF TOP DRESSING FILL MAY VARY BY UP TO 0.15m.
- EXISTING TREES TO BE REMOVED.
- 15m DESALINATION PIPELINE EASEMENT
- 6m DESALINATION PIPELINE BUFFER



Scale 1:500 @ A1

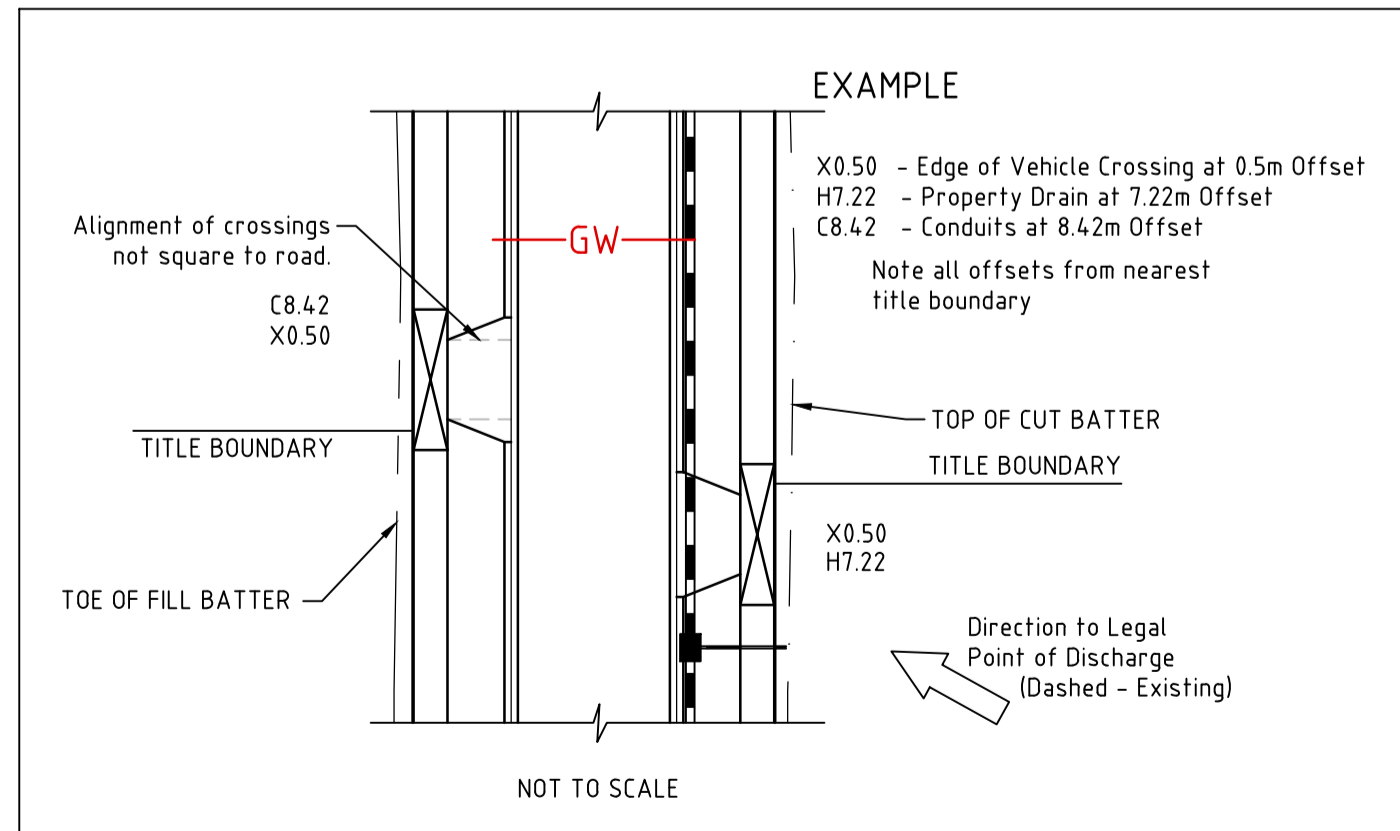

WARNING
BEWARE OF UNDERGROUND SERVICES
THE LOCATIONS OF UNDERGROUND SERVICES ARE APPROXIMATE ONLY AND THEIR EXACT POSITION SHOULD BE PROVEN ON SITE. NO GUARANTEE IS GIVEN THAT ALL EXISTING SERVICES ARE SHOWN.

CONSTRUCTION PLAN

THIS DRAWING IS NOT TO BE COPIED OR SCALED

VERSION	REMARKS	DATE	BY
N	DETAILS IN DESAL EASEMENT REVISED	19.08.21	BB
M	BRIDGE REMOVAL AND LOT 14.4 DRIVEWAY CHANGED	22.07.21	ST
L	LOTS 14.4-14.7 AMENDED	14.05.21	ST
K	NOTE ADDED REGARDING GAS MAIN CROSSING	14.05.21	JZ
J	COUNCIL COMMENTS	26.04.21	KM

LEGEND

	RAIN, PROPERTY INLET & PIT		RECYCLED WATER
	SEWER AND MAINTENANCE HOLE		ELECTRICAL U.G. SERVICES
	WATER MAIN		ELECTRICAL SERVICE & PIT
	EX WATER MAIN, VALVE & HYDRANT		EX ELECTRICAL ASSETS
	EX GAS MAIN, VALVE		EX ELECTRICAL OVERHEADS
	TELSTRA SERVICES & PITS		GAS & WATER CONDUITS
	TELSTRA SERVICES & PITS		TOP OF BATTER
	TELSTRA SERVICES & PITS		TOE OF BATTER

	FINISHED SURFACE AFTER CUTTING OR FILLING		STREET SIGN DRAINAGE PIT No.
	TOP OF PROPOSED BATTER		TBM
	PROPOSED PAVEMENT OR FOOTPATH SURFACE		EX FENCE
	EXISTING OR PROPOSED INVERT LEVEL OF PIPE OR OPEN DRAIN		EX WALL OR BUILDING
	TANGENT POINT		
	CHAINAGE		
	PSM		

DRAWN BY	N. ROBINSON	DESIGNED BY	J. BOSCO
MELWAY	131, D10	CHECKED BY	
DATUM	AHD	AUTHORISED BY	S. RAVIDA

REEDS CONSULTING

LAND SURVEYING
CIVIL ENGINEERING
PLANNING
DEVELOPMENT CONSULTING

www.reedsconsulting.com.au
engineering@reedsconsulting.com.au

Lvl 4, 440 Elizabeth Street Melbourne Victoria 3000
p (03) 8640 3000

CITY OF CASEY
HONOUR VILLAGE ESTATE
STAGE 1
LAYOUT PLAN 1

DRAWING No.	1R2	VERSION	N
REFERENCE	22344E/1		
SHEET	2 OF 41		

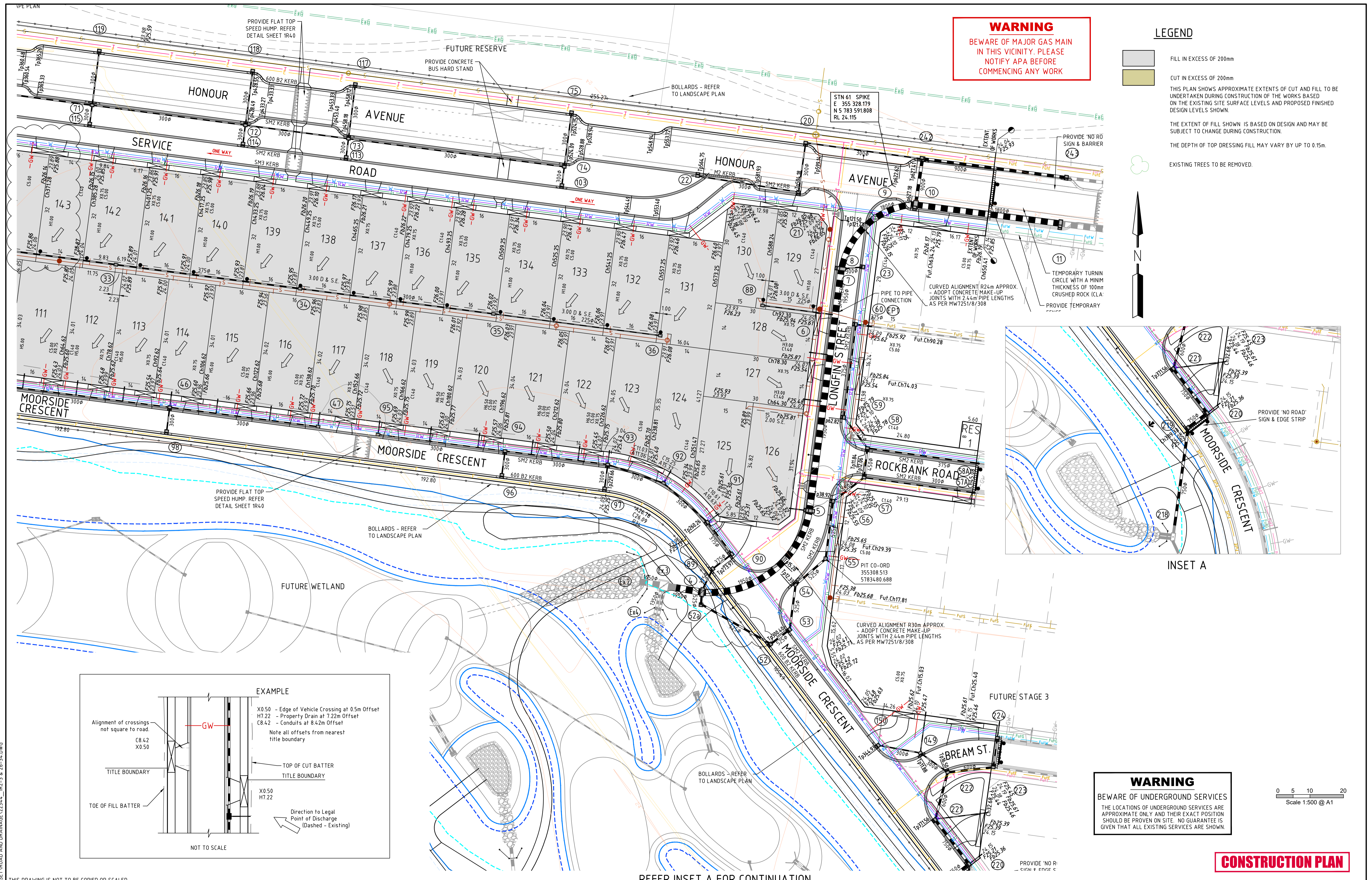

WARNING
BEWARE OF MAJOR GAS MAIN
IN THIS VICINITY. PLEASE
NOTIFY APA BEFORE
COMMENCING ANY WORK

LEGEND

- FILL IN EXCESS OF 200mm
- CUT IN EXCESS OF 200mm
- THIS PLAN SHOWS APPROXIMATE EXTENTS OF CUT AND FILL TO BE UNDERTAKEN DURING CONSTRUCTION OF THE WORKS BASED ON THE EXISTING SITE SURFACE LEVELS AND PROPOSED FINISHED DESIGN LEVELS SHOWN.
- THE EXTENT OF FILL SHOWN IS BASED ON DESIGN AND MAY BE SUBJECT TO CHANGE DURING CONSTRUCTION.
- THE DEPTH OF TOP DRESSING FILL MAY VARY BY UP TO 0.15m.
- EXISTING TREES TO BE REMOVED.

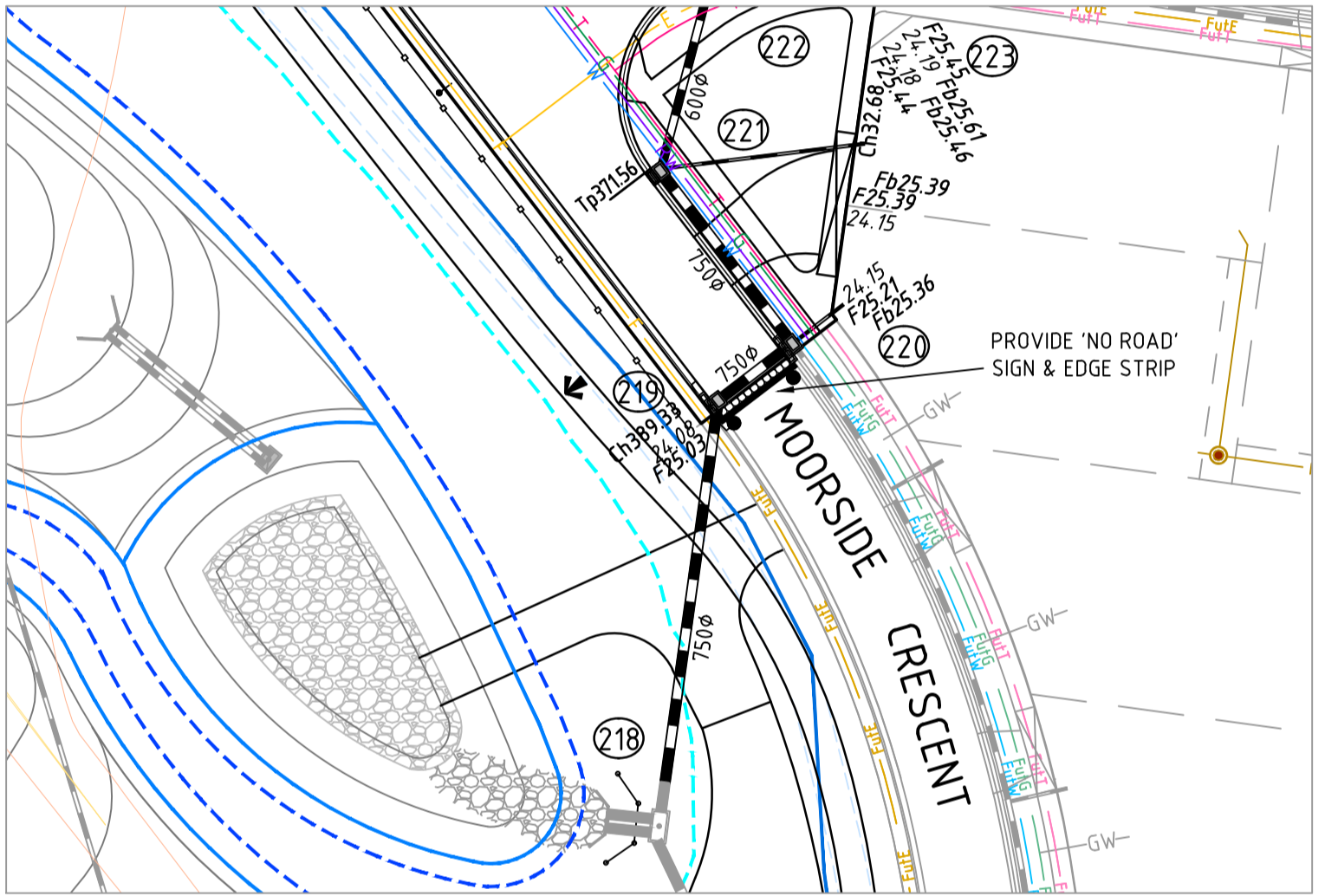

INSET A

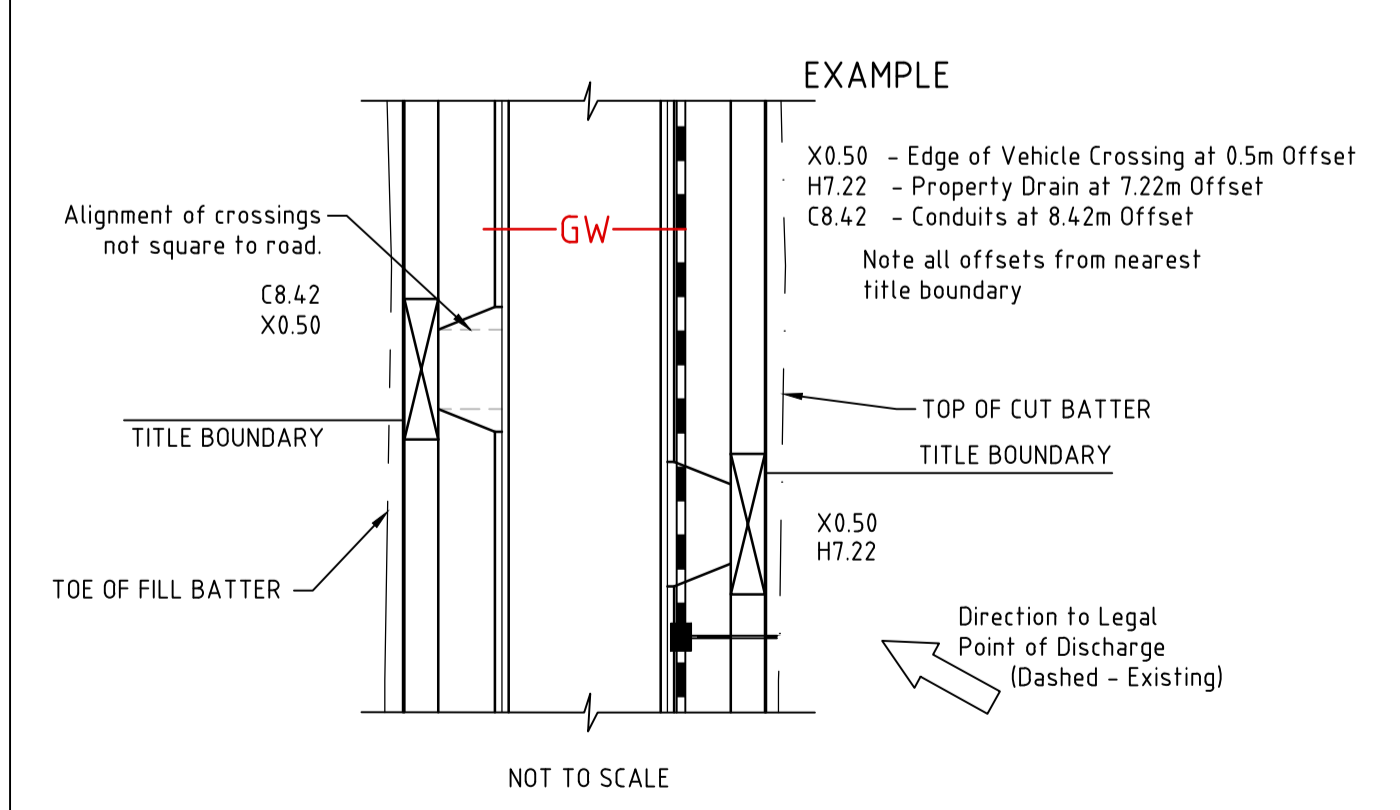

WARNING
BEWARE OF UNDERGROUND SERVICES
THE LOCATIONS OF UNDERGROUND SERVICES ARE APPROXIMATE ONLY AND THEIR EXACT POSITION SHOULD BE PROVEN ON SITE. NO GUARANTEE IS GIVEN THAT ALL EXISTING SERVICES ARE SHOWN.

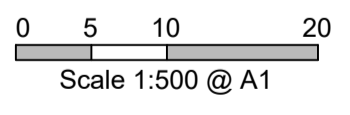

THIS DRAWING IS NOT TO BE COPIED OR SCALED

REFER INSET A FOR CONTINUATION

VERSION	REMARKS	DATE	BY	CHK
K	PIT 52a RELOCATED	05.08.21	KM	
J	PRAM CROSSING RELOCATED AND LOT 144 DRIVEWAY CHANGED	22.07.21	JB	
H	LOTS 14.4 - 14.7 AMENDED	14.05.21	ST	
G	PIT EX 2 TO PIT 5 AMENDED	05.05.21	JZ	
F	COUNCIL COMMENTS	26.04.21	KM	

LEGEND

- RECYCLED WATER
- EX RECYCLED WATER
- ELECTRICAL U.G. SERVICES
- EX ELECTRICAL U.G. SERVICES
- WATER MAIN
- EX WATER MAIN, VALVE & HYDRANT
- GAS MAIN
- EX GAS MAIN, VALVE
- TELSTRA SERVICES & PITS
- EX TELSTRA SERVICES & PITS
- TOP OF BATTER
- TOE OF BATTER

- FINISHED SURFACE AFTER CUTTING OR FILLING
- TOP OF PROPOSED BATTER
- PROPOSED PAVEMENT OR FOOTPATH SURFACE
- EXISTING OR PROPOSED INVERT LEVEL OF PIPE OR OPEN DRAIN
- TANGENT POINT
- CHAINAGE
- PSM
- EX FENCE
- EX WALL OR BUILDING

DRAWN BY	N. ROBINSON	DESIGNED BY	J. BOSCO
MELWAY	131, D10	CHECKED BY	
DATUM	AHD	AUTHORISED BY	S. RAVIDA

REEDS CONSULTING

www.reedsconsulting.com.au
 engineering@reedsconsulting.com.au

LAND SURVEYING
 CIVIL ENGINEERING
 PLANNING
 DEVELOPMENT CONSULTING

Lvl 4, 440 Elizabeth Street Melbourne Victoria 3000
 p (03) 8640 3000

CITY OF CASEY
 HONOUR VILLAGE ESTATE
 STAGE 1
 LAYOUT PLAN 2

DRAWING No.	1R3	VERSION	K
REFERENCE	22344E/1		
SHEET	3 OF 41		